

THIEL

PowerPlane® 1.2

Coherent Source®
in-wall loudspeaker system



OWNER INFORMATION

Congratulations on your purchase of the THIEL PowerPlane® 1.2 in-wall loudspeaker. This product is the result of a dedicated effort to provide very accurate and realistic sound reproduction from a versatile, easy-to-place loudspeaker. We have used very high quality components and taken great care in the PowerPlane 1.2's construction. Properly installed and used with good associated equipment, the PowerPlane 1.2 will provide you with a great deal of sonic enjoyment for many years.



Jim Thiel, Product Designer, THIEL Audio

SPEAKER PLACEMENT

The PowerPlane 1.2 is designed to perform well in a variety of locations throughout the room. It can be mounted in walls, ceilings, or in an enclosed cabinet. Because of the coaxial/coplanar driver mounting, the PowerPlane 1.2 can be oriented both horizontally or vertically. For optimum performance, the PowerPlane 1.2 should not be placed very near room corners or where furniture may obstruct the speaker's output.

CONNECTING THE SPEAKERS

The PowerPlane 1.2 uses 5-way binding posts which accept several types of speaker cable termination. *Make sure that all connections are tight.* For proper performance, speakers in a multi-speaker system must be wired in the same polarity. The speaker's input terminals are color coded to facilitate this. The wire connected to the red ringed input terminal of each speaker should connect to the respective positive (+) output terminal of the amplifier; the wire connected to the black ringed input terminal should be connected to the respective negative (-) output terminal of the amplifier. The speakers should be connected to the amplifier with high quality cable to ensure minimal loss of power and proper control by the amplifier.

MOUNTING INSTRUCTIONS

It is important that the PowerPlane 1.2 be mounted rigidly to prevent unwanted vibration, therefore mounting only to the wall material, like drywall, is not recommended. Please consult your THIEL dealer for professional installation. A wall opening template is included with the speaker.

GRILLE

The PowerPlane 1.2's grille is magnetically attached to the cabinet and can be removed by gently prying the grille forward.

PAINTING THE FRONT PANEL

The PowerPlane 1.2 is shipped with an off-white finish, but can be painted any desired color. To protect the driver during painting, first remove the grille and then remove the driver trim ring by removing the six ring mounting screws. Place the included paper painting mask over the driver, then place the trim ring on top of the mask.



Painting Mask Placement

ASSOCIATED EQUIPMENT

The PowerPlane 1.2 is a very high quality sound reproducer and will benefit from use with high quality associated equipment. Since it is extremely accurate, it will reveal sources of distortion generated elsewhere in the system. For example, distortion resulting from poor recordings or inferior electronics will be reproduced accurately.

POWER REQUIREMENTS

It is important to have enough power to play at the level you desire without distortion. If high sound levels are desired, the PowerPlane 1.2s are designed to be used with amplifiers rated up to 200 watts per channel (into 8 ohms). If you play the speakers more loudly than the volume the amplifier can cleanly produce, the amplifier will produce overload (clipping) distortion. The sound will become compressed, strained, and in extreme cases, obviously distorted. This distortion is actually non-musical *additional energy* and since it is concentrated in the high frequency region where the speaker is least able to handle it, tweeters can be damaged in extreme cases.

Keep in mind that sound *quality* is usually much more important than sound *quantity*. There can be large differences in the sonic performance of two amplifiers of equal power, and this is more important than large differences in power. Most everyone will be happier with a 100 watt amplifier of high sonic quality than a 200 watt amplifier of mediocre sonic quality. For this reason, we feel there is no substitute for listening in making your amplifier decision.

The question “how much power do I need?” does not have the simple answer most people expect because it is not determined only by the loudspeaker’s efficiency, but also by the volume desired and the size of the room. If all three factors are average, about 100 watts per channel is required. Each factor can raise or lower this amount by about three times.

1) Usually, people who “don’t like music loud” can decrease their power to about one-half. Also, people who like music loud should increase their power by 2 times or more. Most people fall within a normal range.

2) A speaker with a low efficiency of 84 dB/W-m will require twice the power of an average 87 dB/W-m speaker and one with a high rating of 90 dB/W-m will require only half the power of an average speaker. The PowerPlane is of above average efficiency (89 dB) and therefore requires less than an average amount of power for average volume levels.

3) A small room will need less power for a given loudness level than a large room. A very small room of 1000 cu ft (11' x 11' with an 8' ceiling) will require about half the power of an average size room. A large room of 6000 cu ft (20' x 30' with a 10' ceiling) will require twice the average power. If the listening room is connected to another room by a large open area, the required power will increase, but not by the amount of the combined room volume. If the room has a “dropped” ceiling with light panels, the ceiling will be almost transparent acoustically and the space above the ceiling should be added. If the panels are heavy they will act as a more normal ceiling.

With all this in mind, a person who doesn’t like to play music very loudly and has a small room can get quality sound with the PowerPlane with as little as 30 watts whereas a person who sometimes likes to play loudly and has a large room may need 200 watts or more.

BREAK-IN

The PowerPlane 1.2, like most speakers, requires a period of playing before they perform optimally. The time depends on how loudly the speakers are played; more time is required if played softly, less if played loudly. At least 50 hours at moderately loud levels are required before the speaker is performing near optimum.

SERVICE

If your speaker system requires service, contact your authorized THIEL dealer. If you need to contact THIEL, service information and technical support is available at (859) 254-9427, Monday-Friday, 8:30 a.m. - 5:00 p.m. Eastern Time, or via e-mail at service@thielaudio.com.

POWERPLANE 1.2 CABINET DIMENSIONS

in millimeters and inches

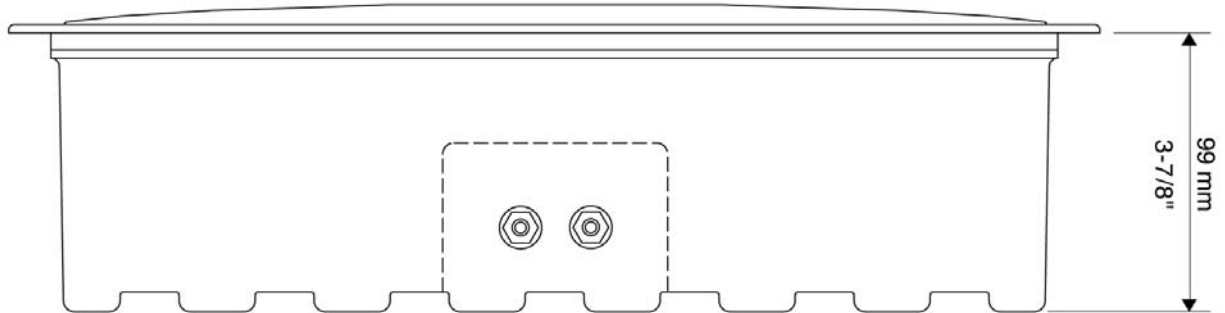

Secure the HigherPlane by tightening the four speaker mounting screws which will tighten the four "Dog" clamps.

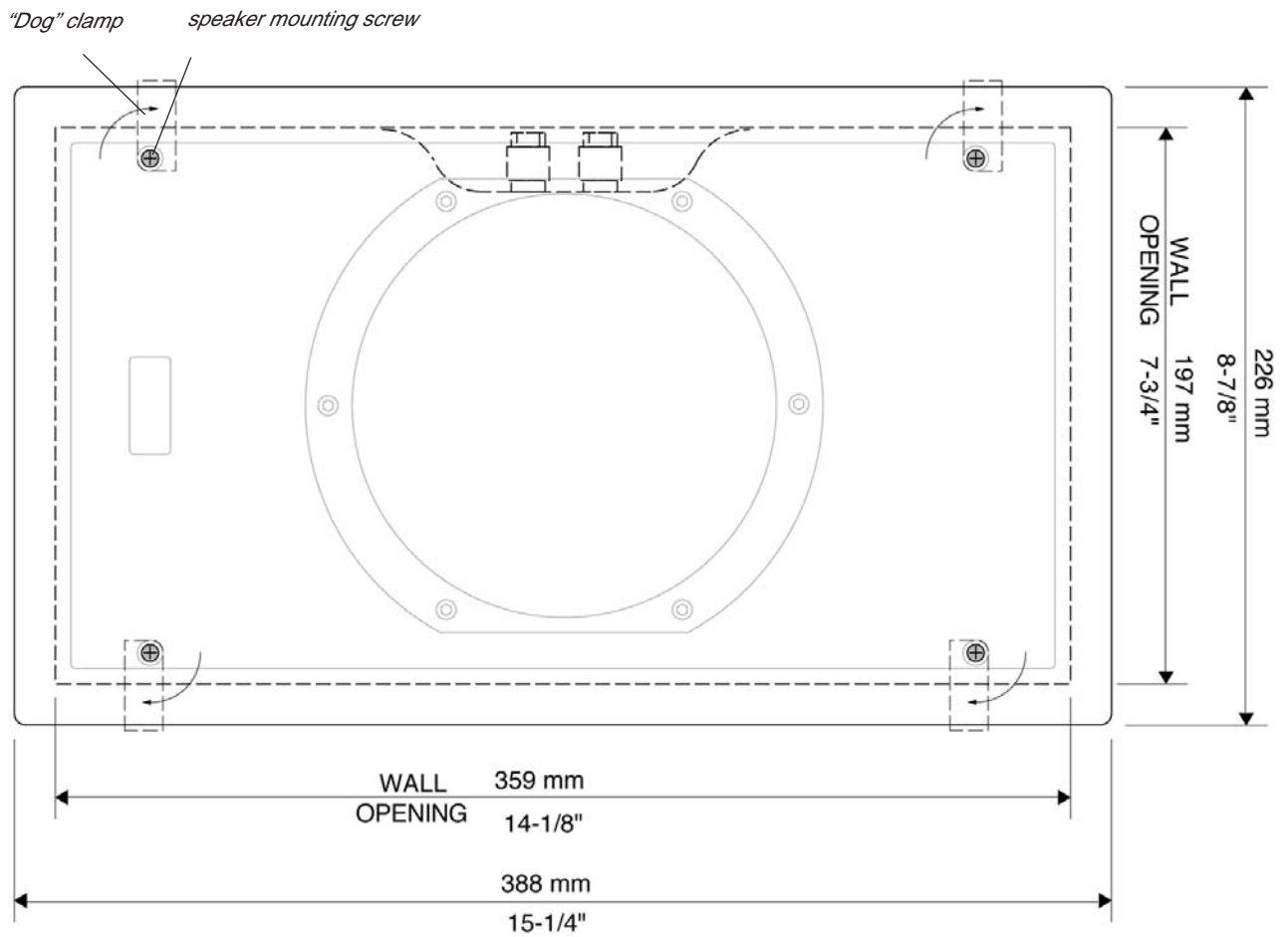

Depth required behind wall surface: 3 7/8". Required wall opening: 7 3/4" x 14 1/8"

THIEL POWERPLANE 1.2 SPECIFICATIONS

Amplitude Response	75 Hz-20 kHz \pm 3 dB
Phase Response	Minimum \pm 10°
Sensitivity	89 dB@2.8 V-1m
Impedance	4 ohms (3 ohms minimum)
Recommended Power	30-200 watts
Size	9" H x 4" D x 15.25" L (horizontal)
Weight	9 pounds

You can also register your warranty online at www.thielaudio.com/wreg.cfm

LIMITED 10 YEAR WARRANTY

THIEL warrants every THIEL PowerPlane 1.2 system against defects in materials and workmanship to the original owner for a period of ten years from the date of purchase. THIEL will, at no charge, replace any defective part and make any repairs necessary to ensure its proper performance when the defective unit is returned to us postpaid.

This warranty does not cover damage due to accident or abuse and is void if the unit has been tampered with.

This warranty is automatic and no registration is required. This warranty gives you specific legal rights. You may also have other rights which are particular to your state.

The following information is for your records.

Serial Numbers _____

Purchase Date _____

Purchased From _____



THIEL

1026 Nandino Boulevard
Lexington, Kentucky 40511-1207
Telephone: 859-254-9427 • E-mail: mail@thielaudio.com • Web: www.thielaudio.com